



INSUCON 2017, Birmingham, UK

# The New Hermetic Power Transformer Generation “Hermetic 2.0”

Authors: T. Stirl, GE Grid Solutions, Germany  
M. Saravolac, GE Grid Solutions, France  
J. Harthun, GE Grid Solutions, Germany

Presented by Ray Bardsley, Power Transformers R&D, GE Grid Solutions, UK

# The New Hermetic Power Transformer Generation “Hermetic 2.0”

Presentation Summary

---

## The Hermetic Transformer

- What is a hermetic transformer ?
- GE Grid Solutions history of hermetic transformer development
- The modern hermetic transformer

## Three new developments with hermetic transformers

- Common Oil Volume for Tapchanger and Transformer
- “Plug & Play” Bushings
- Green Transformer with hybrid insulation



# The Hermetic Transformer

# Hermetic Transformer

The NEW Hermetic Power Transformer Generation “Hermetic 2.0”

---

## Transformer with no fluid expansion vessel

Sealed tank with no contact between the fluid and the atmosphere.

## Expansion of the fluid with temperature

may be accommodated by mechanical movement and / or gas cushion above the fluid.

The tank may be under positive (warm fluid) or negative (cold fluid) pressure.

## Advantages

are low maintenance and long life.

## Initial cost premium

but life-cycle cost can be less than free-breathing transformers.

## Very commonly used for distribution transformers

but increasingly an option for Medium Power Transformers.

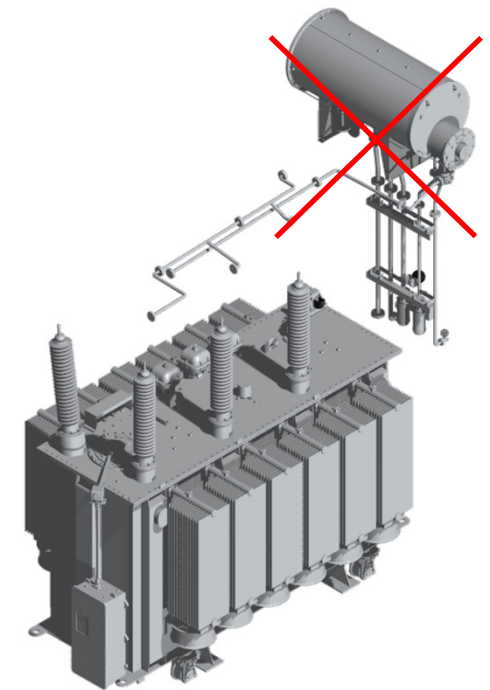

# Hermetic Transformers - GE's Grid Solutions Experience

## The NEW Hermetic Power Transformer Generation "Hermetic 2.0"

Year	
1960	Development of hermetic distribution transformers 50 – 1600 kVA in corrugated sheet steel tanks
1970	Range extended to 6300 kVA
1982	10MVA with expanding radiators to accommodate fluid expansion
2000	Development of hermetic Medium Power Transformers up to 80MVA / 110kV
2006	First hermetic above 100MVA rating. Also first hermetic at 230 kV rating
2007	First hermetic transformer filled with natural ester fluid (31.5 MVA 110 kV)
2010	10 years experience with Medium Power Transformers – more than 100 in service.
2010	Development of common oil space for tapchanger and main transformer tank
2014	Development of 2 <sup>nd</sup> Generation "Hermetic 2.0" – optimised operational behaviour
2015	>1000 years operational service . Excellent reliability.
2016	Development of "Plug & Play" concept for Hermetic transformer terminations.



# Hermetic Transformer

The NEW Hermetic Power Transformer Generation “Hermetic 2.0”

---

- No fluid conservator
- Sealed unit
- No dehydrating breather
- No gas cushion
- Fluid expansion using expanding radiators
- Vacuum switching tapchanger
- Tapchanger diverter compartment fluid connected to main tank fluid
- Special fluid sampling valves

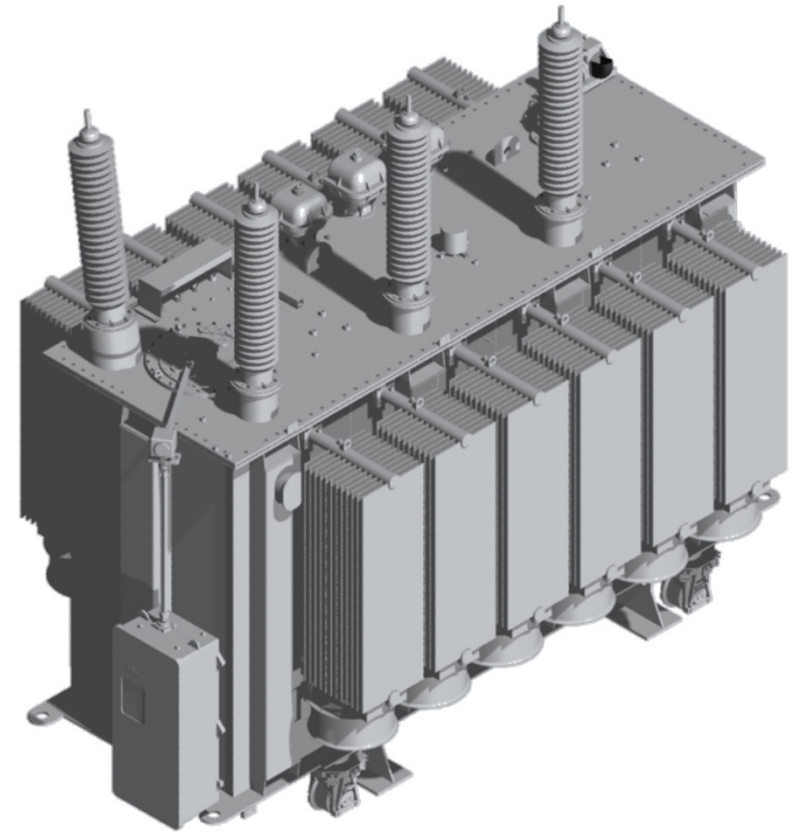

# Common Oil Volume for Tapchanger

# Common Oil Volume for Tapchanger

## The NEW Hermetic Power Transformer Generation “Hermetic 2.0”

Modern On-load Tapchangers (OLTC) switch current inside vacuum bottles, and so produce no carbon. If the OLTC transition resistors are rated so as to limit their temperature during switching there will be no production of dissolved gas in the oil.

The tapchanger can therefore share the same oil volume as the active part.

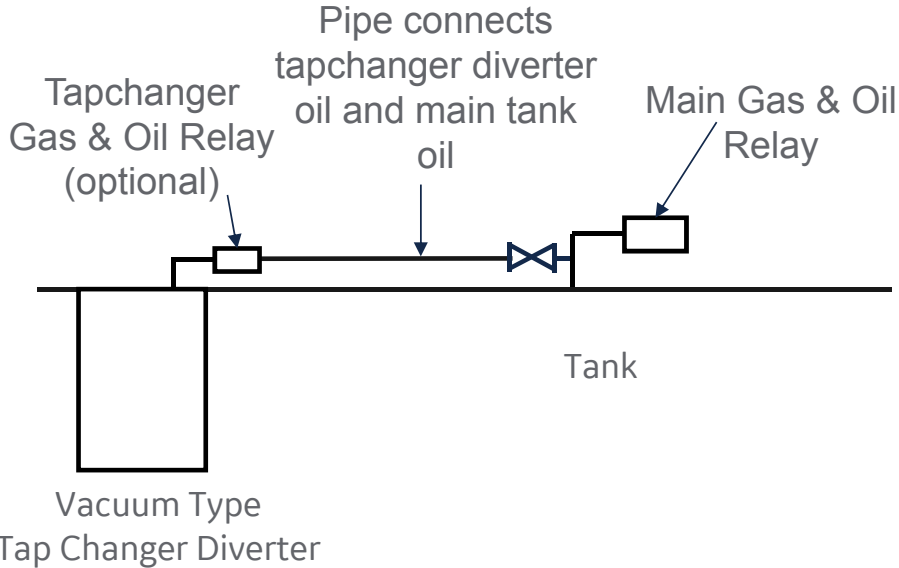
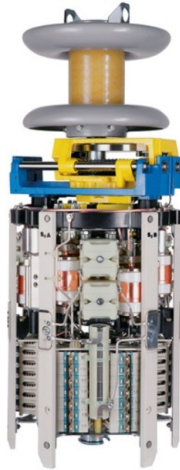

# Common Oil Volume for Tapchanger

The NEW Hermetic Power Transformer Generation “Hermetic 2.0”

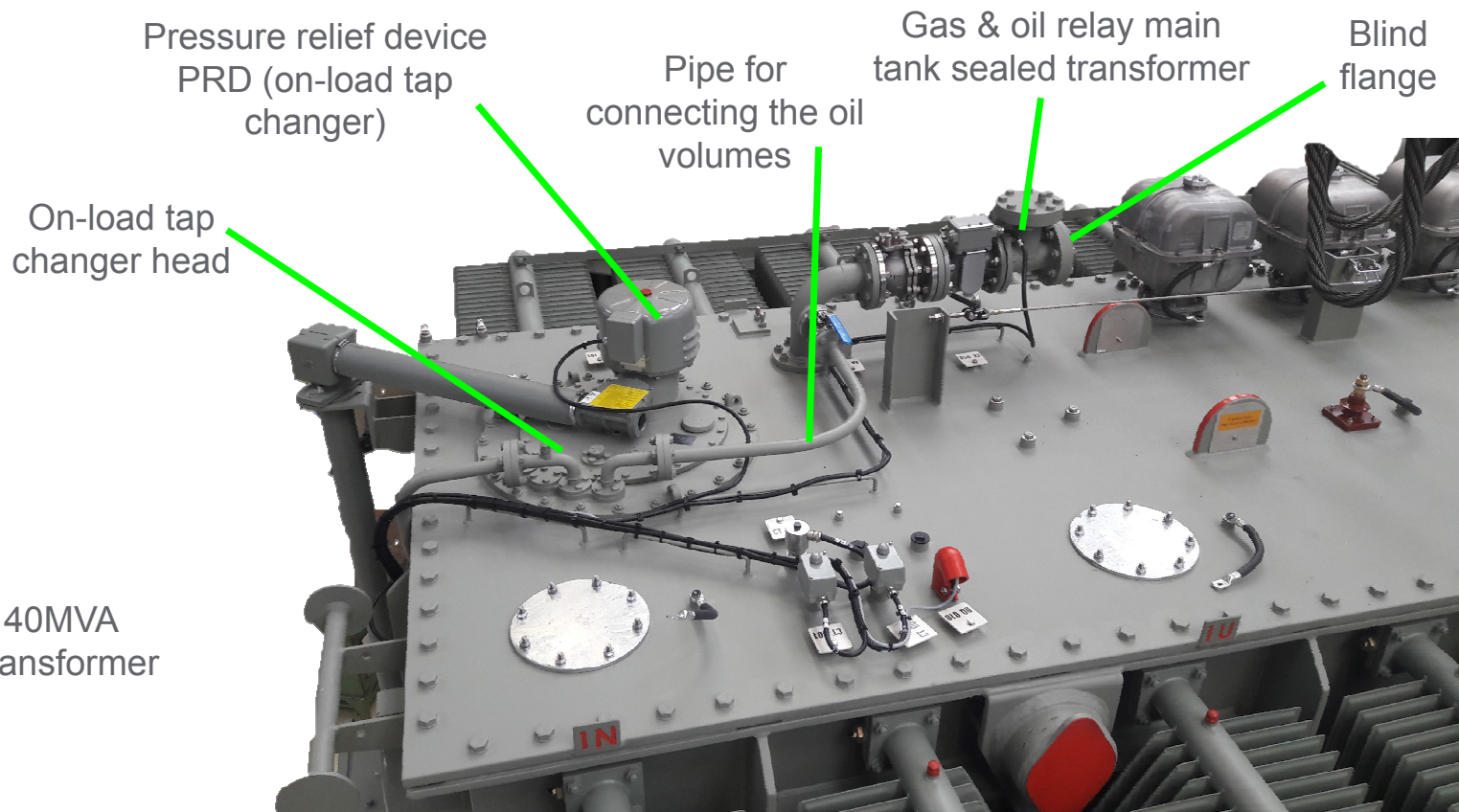

Confidential - Not to be copied, distributed or reproduced without prior approval

# Common Oil Volume for Tapchanger

The NEW Hermetic Power Transformer Generation “Hermetic 2.0”

## Transformer protection strategy.

Double float gas relay common to both tapchanger diverter and main tank (gas alarm & gas trip).

Gas & Oil relay surge trip is not possible due to blind flange (no oil expansion vessel).



Pressure relief device main tank (trip).

Pressure relief device tapchanger head (trip)

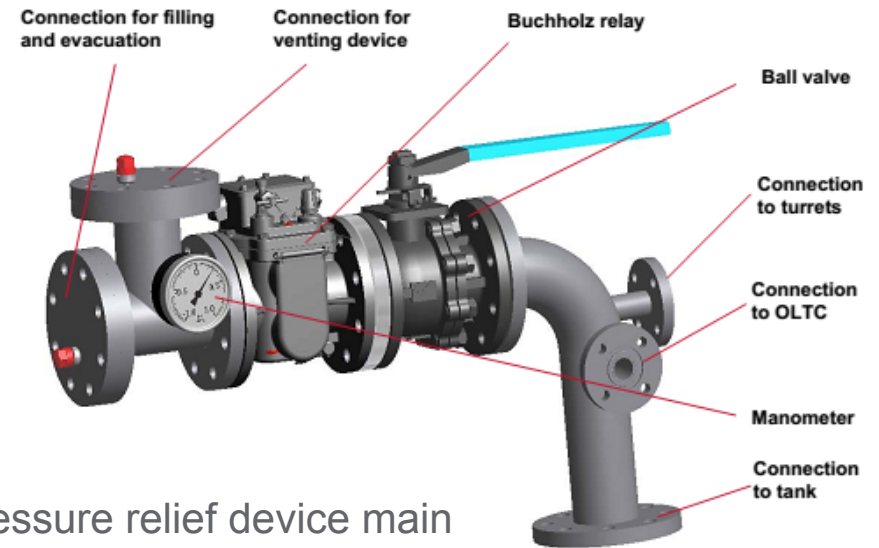

# “Plug & Play” Bushings

# “Plug & Play” Bushings

The NEW Hermetic Power Transformer Generation “Hermetic 2.0”

## At Factory

- Plug-out bushings after FAT
- No oil handling
- No storage of bushings
- Ready for shipment
- No break of hermetic system
- Less assembly hours

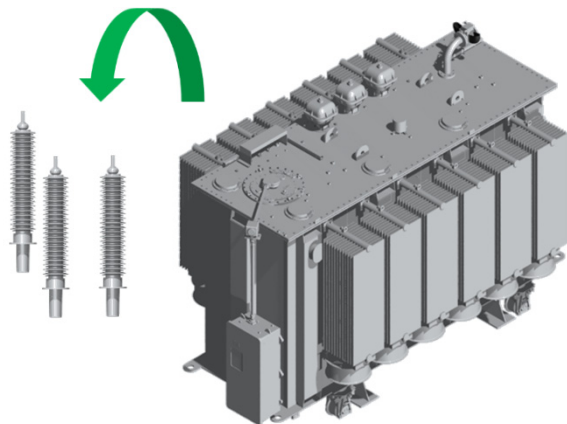

Plug-in type bushing



Socket



## At Site

- Plug-in the bushings
- No commissioning tests
- No oil handling
- Easy transport in case of new site
- Less E&C effort

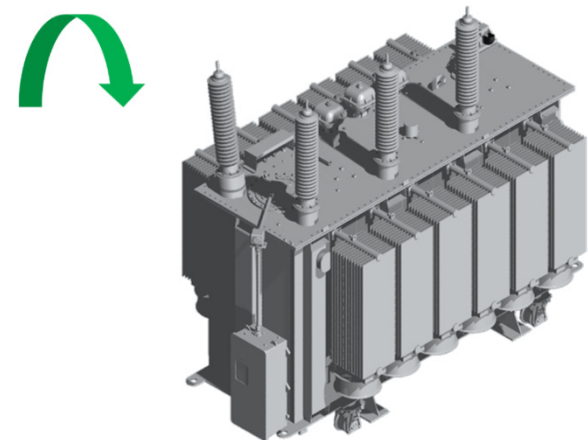

# Green Transformer

# Green Transformer

The NEW Hermetic Power Transformer Generation “Hermetic 2.0”

---

Natural ester fluid has poor oxidation stability – in a Hermetic transformer this is overcome because there is no contact between the fluid and the atmosphere.



Natural esters are vegetable oils directly obtained from renewable plant seeds, are biodegradable & non toxic.  
Excellent “green” credentials

**IEC 62770:2013**

*“ Fluids for electrotechnical applications - Unused natural esters for transformers and electrical equipment ”*

Natural Esters and Hermetic transformers are ideally suited for each other



# Green Transformer

The NEW Hermetic Power Transformer Generation “Hermetic 2.0”

Natural ester in hermetic transformer has dramatic protective effect on ageing of cellulosic insulation.

- Higher water solubility (water held in fluid  
And not in cellulose material)

Max. water solubility@23°C	
Mineral oil	55 ppm
Natural ester	1100 ppm

- Hydrolysis phenomena (trans-esterification):  
Water is consumed by the ester and converted  
Into (non-aggressive) fatty acids.

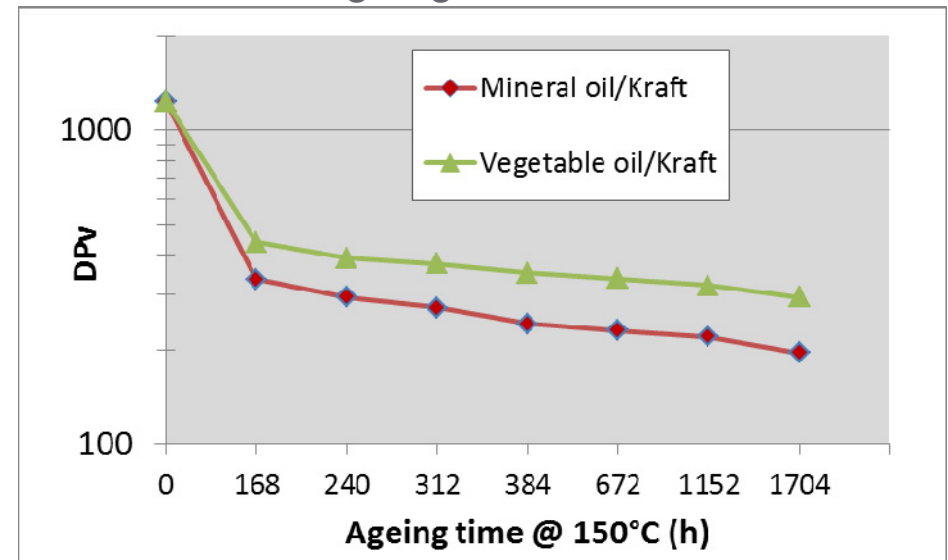

IEC 60076-14 (2013) “Liquid-immersed power transformers using high-temperature insulation materials” allows higher continuous winding hot-spot, average winding and top oil rises than mineral oil / paper.



# Green Transformer

The NEW Hermetic Power Transformer Generation “Hermetic 2.0”



10 MVA 110kV 16.7 Hz Trackside transformer

Incorporates:

- Hermetic transformer with expanding radiators
- Natural ester fluid
- Hybrid insulation (aramid paper conductor insulation, otherwise pressboard and laminated wood)

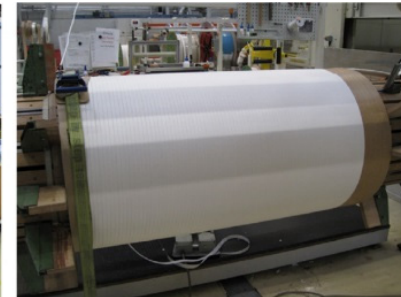

Imagination at work





INSUCON 2017, Birmingham, UK

# The New Hermetic Power Transformer Generation “Hermetic 2.0”

Authors: T. Stirl, GE Grid Solutions, Germany  
M. Saravolac, GE Grid Solutions, France  
J. Harthun, GE Grid Solutions, Germany

Presented by Ray Bardsley, Power Transformers R&D, GE Grid Solutions, UK