



Characteristics of ZnO microvaristors- loaded grading polymeric materials

Maurizio Albano

H. Ahmad, S. Robson, A. Haddad

- Research background : ZnO microvaristors
- Material properties
- Fabrication process
- Experimental set up
- Characterisation of electrical properties : Point-On-Wave (POW) method
- Conclusions

- Ceramic material with non-linear electrical properties (V-I characteristics) that similar to those seen in ZnO surge arresters.
- Flexible – Can be compounded with polymeric insulation material. New generation of grading material are used in high voltage protection, such as at the terminals of high voltage cables, electrical machines and bushings.
- Two different ZnO materials were used; **A** and **B** to fabricate new field grading samples.
Range of grains size:
 - Material **A** (10 μm to 120 μm)
 - Material **B** (up to 300 μm)
- Size of fabricated sample : 50 mm x 50 mm x 5 mm

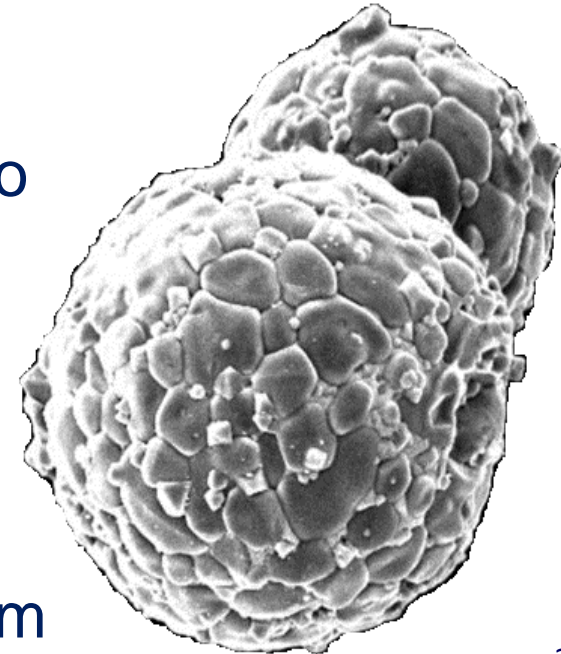

Material preparation

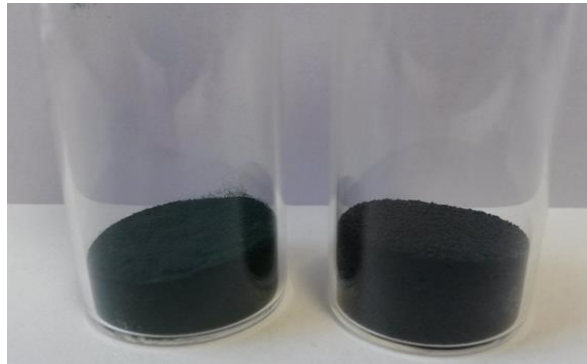

Two ZnO microvaristor powders
A (left) and **B** (right)

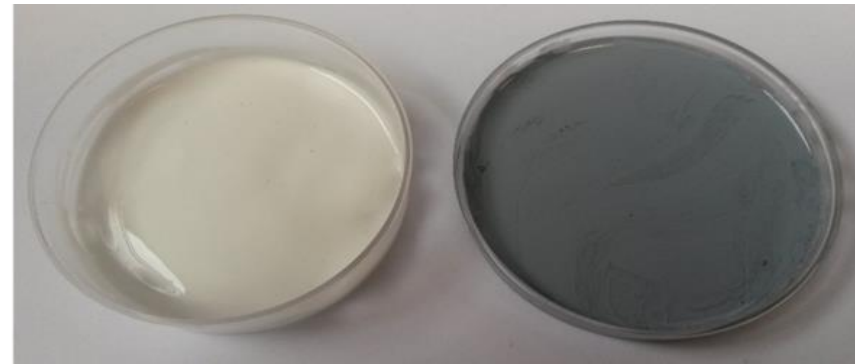

Silicone rubber with hardener
Powersil 600-A (left) and **Powersil 600-B** (right)

Materials	Properties	Inspection method	Value
Silicone rubber	Relative permittivity	IEC 60250	2.9
	Density	IEC 1183-1 A	1.13 g/cm ³
	Volume resistivity	IEC 60093	10 x 10 ¹⁵ W.m
Microvaristor A	Density		5.6 g/cm ³
Microvaristor B	Density		Average 5.6 g/cm ³

Field grading materials : Dispersing microvaristor (non-linear resistive powder) into the matrix carrier at certain (wt.%) or (vol.%) concentration.

Fabrication process

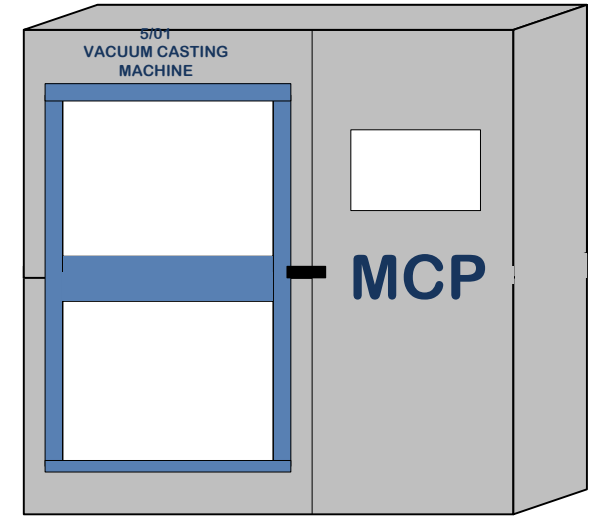
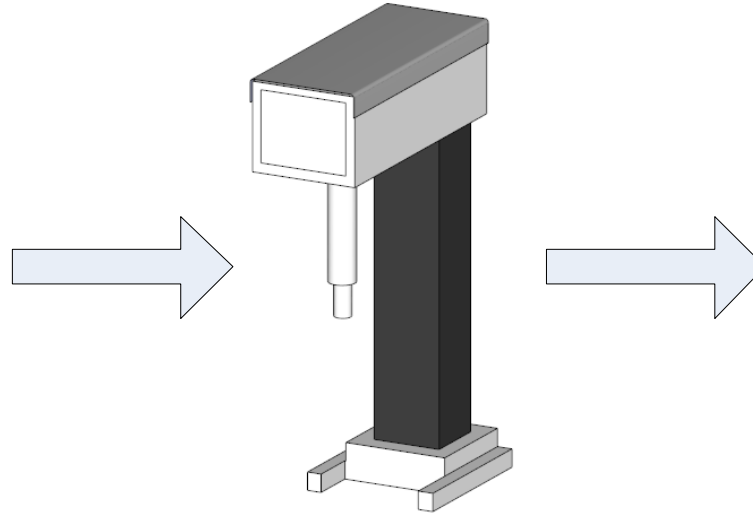
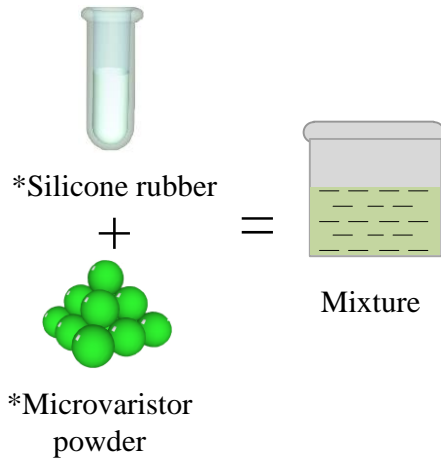

VACUUM CASTING & MOULDING

*after heat treatment

Start

Heat treatment to host matrix and microvaristor powder
50 °C for 1 hour

Mixing host matrix with microvaristor
-variable speed

$$\text{rpm} = \frac{\text{peripheral velocity (m/ sec)} * 60 * 1000}{d(\text{mm}) * \pi}$$

Degassing

Moulding

Curing
50 °C for 4 hours

End

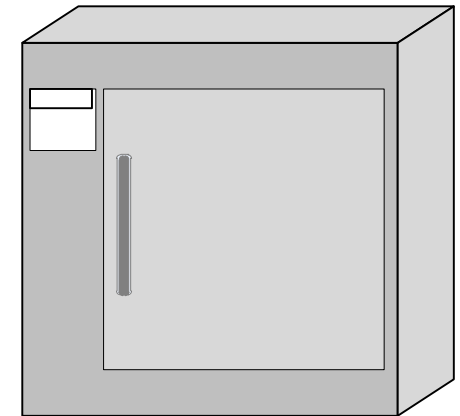

Experimental set up : AC test

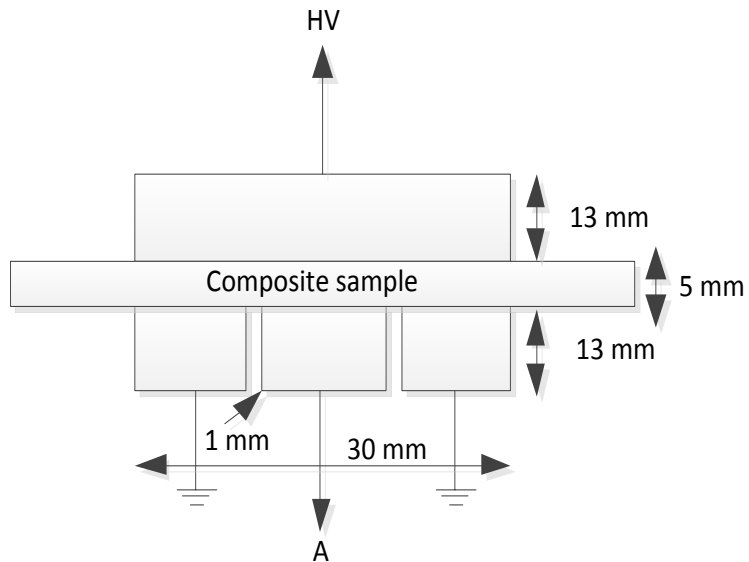
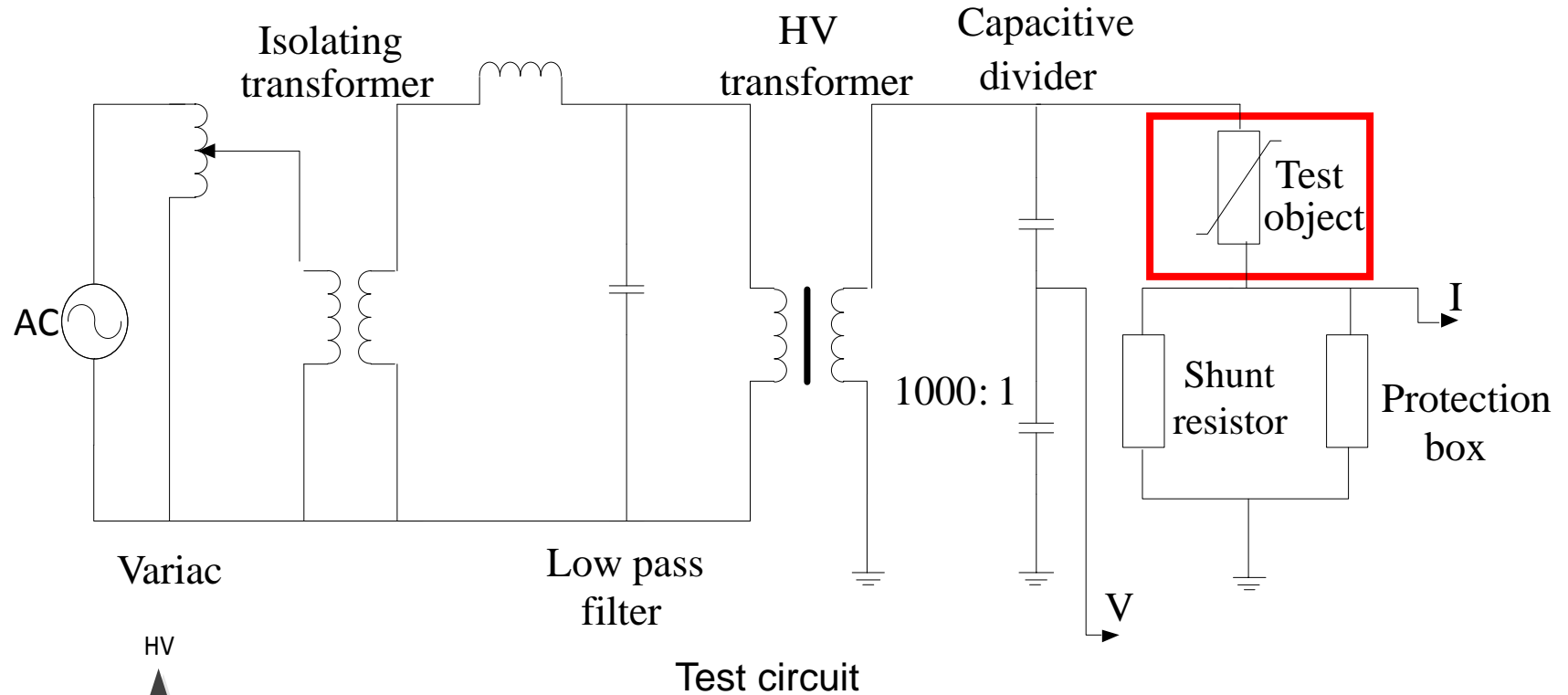

Characterisation of electrical properties : Point-On-Wave (POW) method

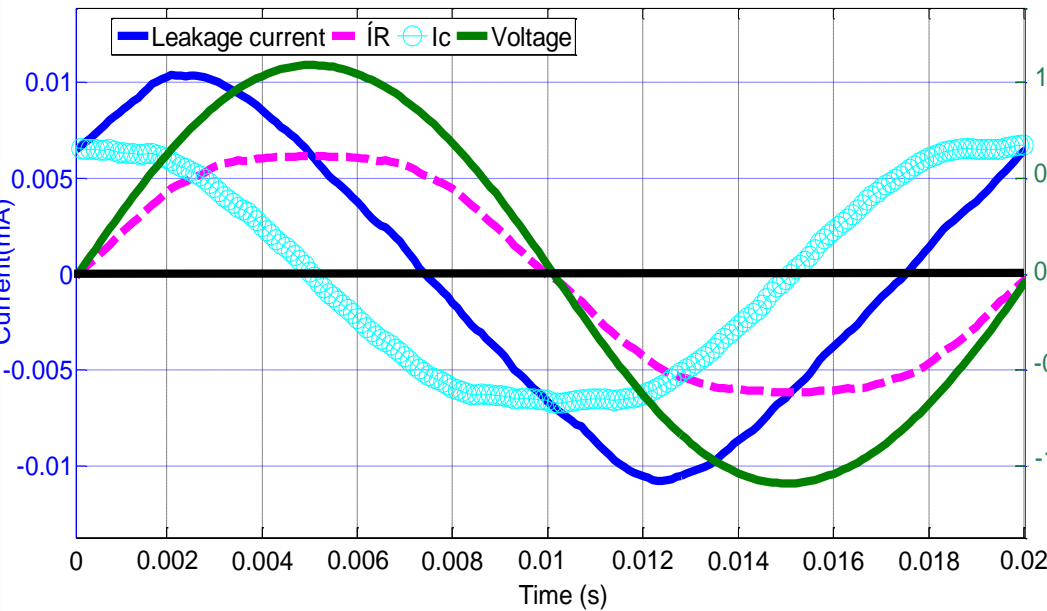

At 1.09 kV_{peak}

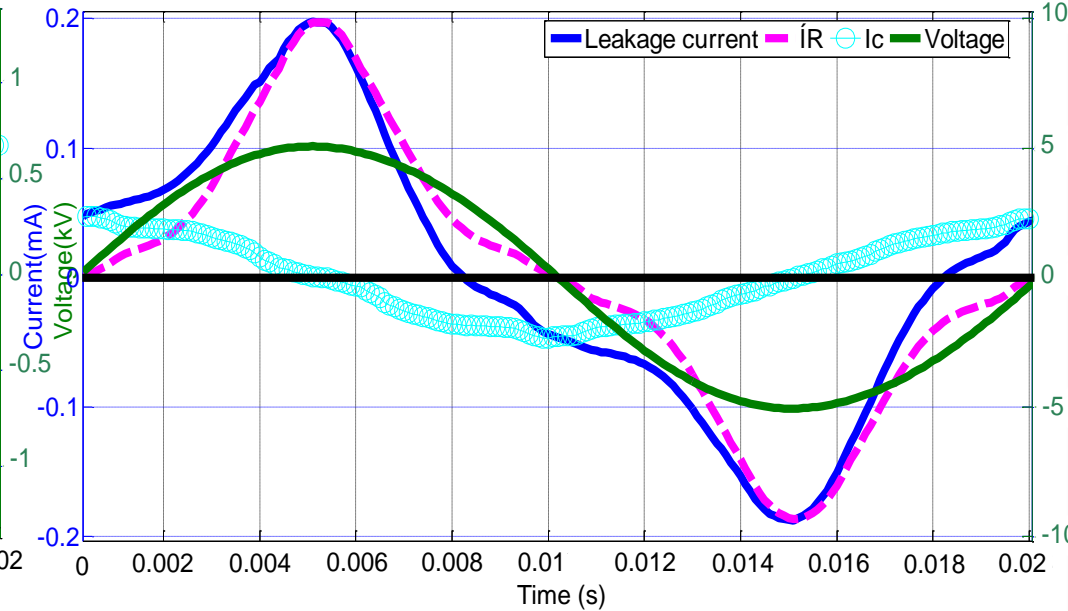

At 5.07 kV_{peak}

Voltage and current of ZnO microvaristor compound **A**

- The leakage current is discriminated into resistive and capacitive components.

$$I_t(t) = I_c(t) + I_r(t) = C \frac{dV(t)}{dt} + I_r(t)$$

Magnitude of the instantaneous leakage current was examined at 2 different times, t_1 and t_2 which correspond to voltage levels having same magnitude and polarity.

- The electrical properties of microvaristor powder and compound of ZnO microvaristors are presented in the graphs below.

Electrical properties

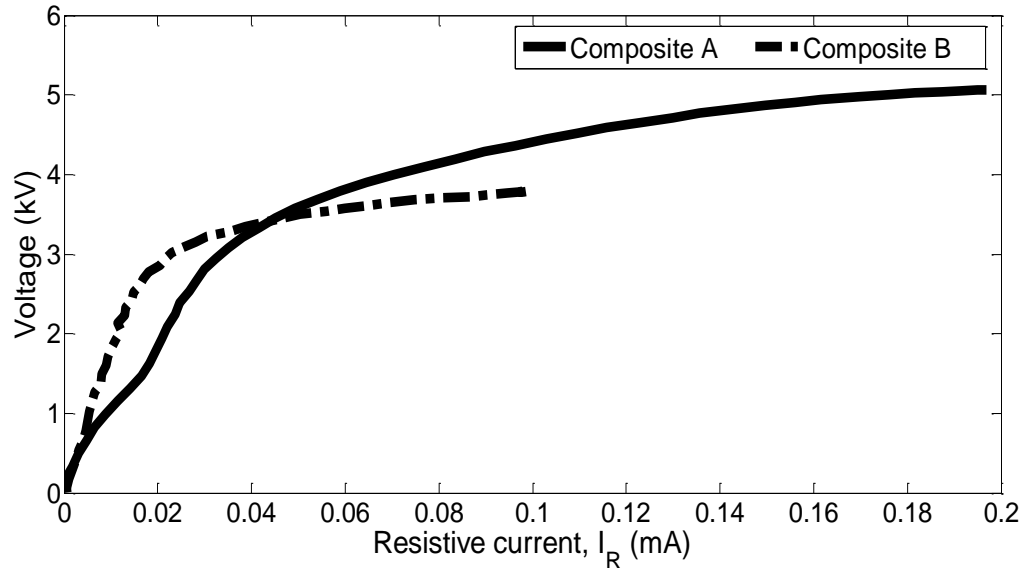

Measured V-I characteristics for ZnO compounds A and B into the breakdown regime

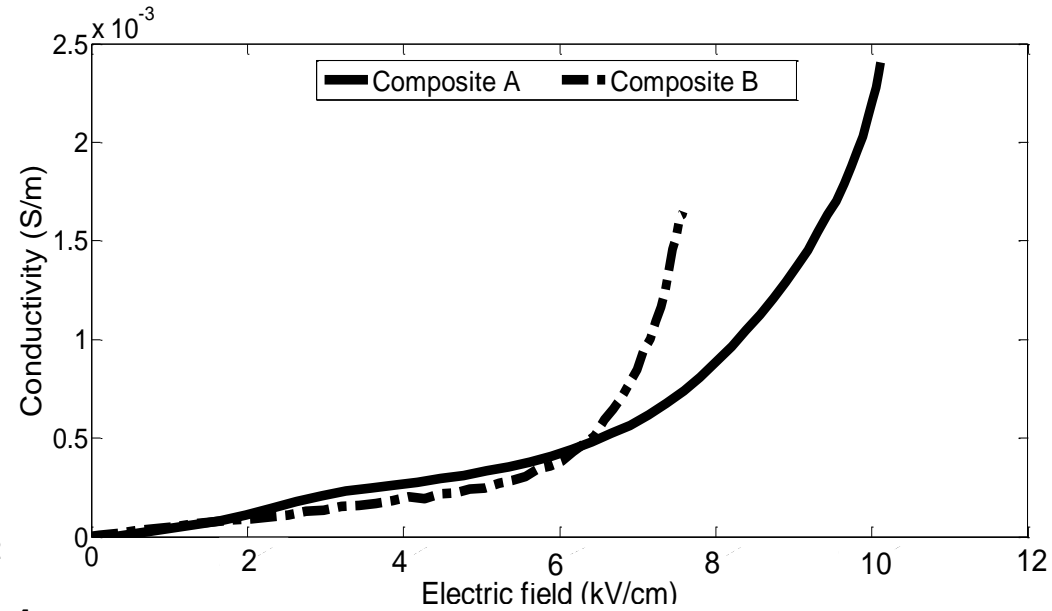

Conductivity versus electrical field.

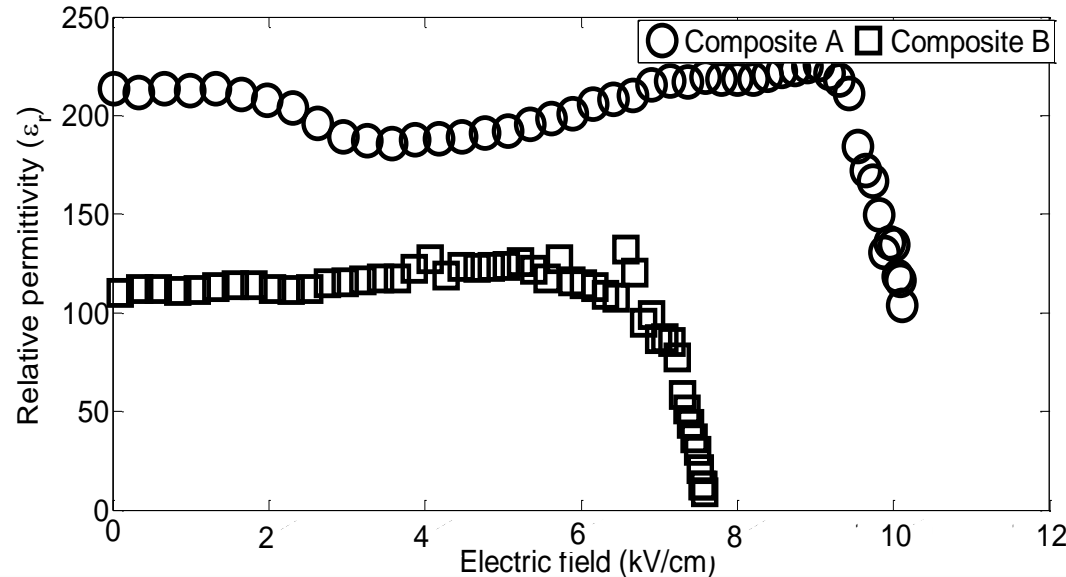

Relative permittivity values as function of the electrical field for microvaristor compounds.

- A new fabrication method of in-house field grading materials (FGM) was proposed with the introduction of an additional procedure - heat treatment to the ZnO microvaristor grains.
- The non-linearity of the compound was obtained at 70 wt.% microvaristor concentration for both materials **A** and **B** when reached at certain threshold voltages.
- The **Point On Wave (POW)** method was applied to discriminate the resistive and capacitive component from leakage current. The electrical properties were derived through a current analysis technique.

Thank You